

PREPARED BY:	DATE
APPROVED BY:	DATE

# SHARP

LIQUID CRYSTAL DISPLAY GROUP  
SHARP CORPORATION

## SPECIFICATION

SPEC No. LD-7205

FILE No.

ISSUE: FEB. 221995

PAGE : pages

APPLICABLE GROUP

Liquid Crystal Display  
Group

DEVICE SPECIFICATION FOR  
**TFT - LCD' module**  
MODEL No.  
**LQ64D 141**

CUSTOMER'S APPROVAL

DATE \_\_\_\_\_

BY \_\_\_\_\_

PRESENTED

BY H. Fukuoka

H. FUKUOKA

Department General Manager

Engineering Department 2

TFT LCD Development Center

LIQUID CRYSTAL DISPLAY GROUP

SHARP CORPORATION

## 1. Application

This specification applies to a color TFT-LCD module, LQ64D141.

## 2. Overview

This module is a color active matrix LCD module incorporating amorphous silicon TFTs (Thin Film Transistors). This module is composed of a low-reflection-type color TFT-LCD panel, driver ICS, control circuit, power SUPPLY circuit and a high-luminance-type backlight unit. Graphics and texts can be displayed on a 640×3×480 dots panel with 4,096 colors by supplying 12 bit data signals(4bit/color), four timing signals, +5.0V DC supply voltage for TFT-LCD panel driving and SUPPLY voltage for backlight.

But, a DC/AC inverter for backlight-driving is NOT built in this module.

Optimum viewing direction of this module is 6 o'clock.

### [Features]

- ⊙ Low power consumption.
- ⊙ Small footprint and thin shape,
- ⊙ Light weight.
- ⊙ Low surface reflection.
- ⊙ High luminance backlight.

## 3. Mechanical Specifications

Parameter	Specifications	Unit
Display size	16 (6.4") Diagonal	cm
Active area	130.6(H)×97.0(V)	mm
Pixel format	640(H)×480(V)	pixels
	(1 pixel = R + G + B dots)	
Pixel pitch	0.204(H)×0.202(V)	mm
Pixel arrangement	R, G, B vertical stripe	
Display mode	Normally white	
Unit outline dimensions *1	175.0(W)×126.5(H)×9.0(D)	mm
Mass	[2501	<b>g</b>
Surface treatment	Anti-glare, hard-coating(2H) and low-reflection(~5%)	

\*1 Note: excluding backlight cables.

The outline dimensions is shown in Fig. 1

## 4. Input Terminals

## 4-1. TFT-LCD panel driving

The module-side connector: DF9BA-31P-1V (Hirose Electric Co., Ltd.)

CN1 The user-side connector :DF9□-31S-1V ( " ), □ is blank, A or B.

Pin No.	Symbol	Function	Remark
1	R0	RED data signal (LSB)	
2	GND		
3	R1	RED data signal	
4	Vsync	Vertical synchronous signal	【Note1】
5	R2	RED data signal	
6	Hsync	Horizontal synchronous signal	【Note1】
7	R3	RED data signal (MSB)	
8	GND		
9	GND		
10	CK	Clock signal for sampling each data signal	
11	G0	GREEN data signal (LSB)	
12	GND		
13	G1	GREEN data signal	
14	NBH	Signal for settle the horizontal display reverse	
15	GND		
16	TST	This should be electrically opened during operation	
17	G2	GREEN data signal	
18	NBV	Signal for settle the vertical display reverse	
19	G3	GREEN data signal (MSB)	
20	GND		
21	IGND		
22	Vcc	+ 5. 0V power supply	
23	B0	BLUE data signal (LSB)	
24	Vcc	+5. 0V power SUPPLY	
25	B1	BLUE data signal	
26	TST	This should be electrically opened during operation	
27	GND		
28	ENAB	Signal to settle the horizontal display position	【Note2】
29	B2	BLUE data signal	
30	GND		
31	B3	BLUE data signal (MSB)	



CN1 pin arrangement from module surface

※The shielding case is connected with GND in the □odule.

【Note1】 One of 480-, 400- and 350-line mode is selected depending on the polarity combination of the both synchronous signals.

mode	480-line	400-line	350-line
Hsync	negative	negative	positive
Vsync	negative	positive	negative

【Note2】 The horizontal display start timing is settled in accordance with a rising edge of ENAB signal. In case ENAB is fixed “Low”, the horizontal display start timing is determined as described in 7-2. Do not keep ENAB “High” during operation.

## 4-2. Backlight driving

The module-side connector : BHR-03VS-1(JST)

CN2, CN3 The user-side connector : SM02(8.O)B-BHS(JST)

Pin no.	symbol	function
1	V <sub>HIGH</sub>	Power supply for lamp (High voltage side)
3	V <sub>LOW</sub>	Power supply for lamp (Low voltage side)

## 5. Absolute Maximum Ratings

Parameter	Symbol	Condition	Ratings	Unit	Remark
Input voltage	v,	Ta=25℃	-0.3 ~ Vcc+0.3	v	【Note1】
Vcc supply voltage	Vcc	Ta=25℃	0 ~ +7	V	
Storage temperature	Tstg	-	-25 ~ +60	℃	【Note2】
Operating temperature (Ambient)	Topa	-	0 ~ +50	℃	

【Note1】 CK, R0~R3, G0~G3, B0~B3, Hsync, Vsync, ENAB, NBH, NBV

【Note2】 Humidity: 95%RH Max. at Ta≤40℃.

Maximum wet-bulb temperature at 39℃ or less at Ta>40℃.

No condensation.

## 6. Electrical Characteristics

6-1. TFT-LCD<sub>panel</sub> driving

Ta=25℃

Parameter		Symbol	Min.	Typ.	Max.	Unit	Remark
Vcc	Supply voltage	Vcc	+4.5	+5.0	+5.5	V	【Note1】
	Supply current	Icc	-	[130]	[300]	mA	【Note2】
Permissive input ripple voltage		V <sub>RP</sub>	-	-	100	mVp-p	Vcc
Input voltage (Low)		V <sub>IL</sub>	-	-	0.3VCC	v	【Note3】
Input voltage (High)		V <sub>IH</sub>	0.7VCC	“	-	v	
Input current (low)		I <sub>OL1</sub>	-	-	1.0	μA	V <sub>i</sub> =0V 【Note4】
		I <sub>OL2</sub>	-	-	60.0	μA	v <sub>i</sub> =0V 【Note5】
Input current (High)		I <sub>OH1</sub>	-	-	1.0	μA	V <sub>i</sub> =Vcc 【Note6】
		I <sub>OH2</sub>	-	-	60.0	μA	v <sub>i</sub> =Vcc 【Note7】

**【Note1】**

Vcc-turn-on conditions

$t_1 \leq 10\text{msec}$

$0 < t_2 \leq 10\text{msec}$

$0 < t_3 \leq 1\text{sec}$

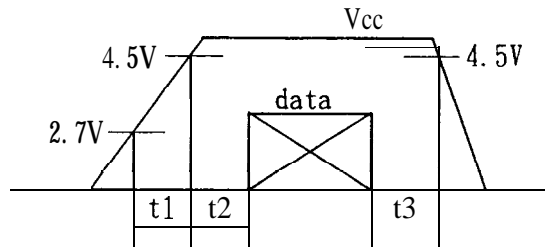

Vcc-dip conditions

1)  $2.7\text{V} \leq V_{cc} < 4.5\text{V}$

$t_d \leq 10\text{msec}$

2)  $V_{cc} < 2.7\text{V}$

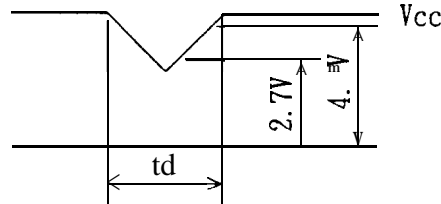

Vcc-dip conditions should also follow the Vcc-turn-on conditions

**【Note2】** The typical value of  $I_{cc}$  is measured in the following condition.GSO pattern.  $V_{cc} = +5.0\text{V}$ 

All of the timing parameters are typical value (480 line mode).

**【Note3】** CK, R0~R3, G0~G3, B0~B3, Hsync, Vsync, ENAB, NBH, NBV**【Note4】** CK, R0~R3, G0~G3, B0~B3, Hsync, Vsync, ENAB, NBV**【Note5】** NBH**【Note6】** CK, R0~R3, G0~G3, B0~B3, Hsync, Vsync, NBH**【Note7】** ENAB, NBV**6-2. Backlight driving**

The backlight system is an edge-lighting type with two CCFTs (Cold Cathode Fluorescent Tube). The characteristics of one lamp installed in the module are shown in the following table.

 $T_a = 25^\circ\text{C}$ 

Parameter	Symbol	Min.	Typ.	Max.	Unit	Remark
Lamp current range	$I_L$	[2.5]	-	[5.51]	mArms	<b>【Note1】</b>
Lamp power consumption	$P_L$	-	[1.31]	-	w	<b>【Note2】</b>
Lamp frequency	$F_L$	20	-	60	kHz	<b>【Note3】</b>
Kick-off voltage	$V_s$	-	-	[800]	V rms	$T_a = 25^\circ\text{C}$
				900	V rms	$T_a = 0^\circ\text{C}$
Lamp life time	$L_L$	10000	-	-	hour	<b>【Note4】</b>

**【Note1】** Lamp current is measured with a current meter for high frequency as shown below.

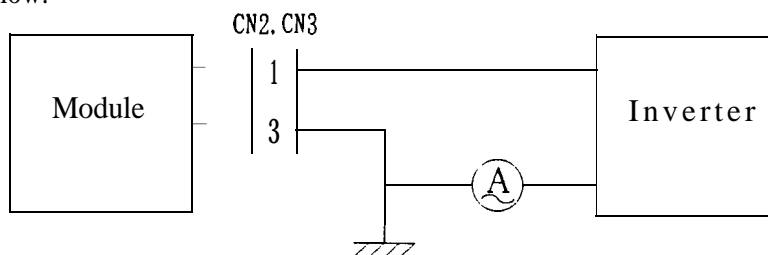
\*3pin is  $V_{L,0W}$

【Note2】 At the condition;  $Y_L=120\text{cd/m}^2$

【Note3】 Lamp frequency may produce interference with horizontal synchronous frequency, and this may cause beat on the display. Therefore lamp frequency shall be detached as much as possible from the horizontal synchronous frequency and from the harmonics of horizontal synchronous to avoid interference.

【Note4】 Lamp life time( $L_L$ ) is defined as the time when either ① or ② occurs in the continuous operation under the condition of  $T_a=25^\circ\text{C}$  and  $I_L=[3.2]\text{mA}_{\text{rms}}$ .

① Brightness becomes 50% of the original value.

② Kick-off voltage at  $T_a=0^\circ\text{C}$  exceeds maximum value, 900  $V_{\text{rms}}$ .

Note) The performance of the backlight, for example life time or brightness, is much influenced by the characteristics of the DC-AC inverter for the lamp. When you design or order the inverter, please make sure that a poor lighting caused by the mismatch of the backlight and the inverter (miss-lighting, flicker, etc.) never occur. When you confirm it, the module should be operated in the same condition as it is installed in your instrument.

## 7. Timing Characteristics of input signals

The timing diagrams of the input signals are shown in Fig.2-①~③.

### 7-1. Timing characteristics

Parameter		Symbol	Mode	Min.	TYP.	Max.	Unit	Remark
Clock	Frequency	1/Tc	all	-	25.18	28.33	MHz	
	High time	Tch	"	5	i -	-	ns	
	Low time	Tcl	"	1	o 1 -	-	ns	
Data	Setup time	Tds	"	5	~ -	-	ns	
	Hold time	Tdh	"	10	-	-	ns	
Horizontal sync. signal	Period	TH	"	30.00	31.78	-	$\mu\text{s}$	
			"	770	800	900	clock	
	Pulse width	THp	"	2	96	200	clock	
Vertical sync. signal	Period	TV	480	515	525	560	line	
			400	445	449	480	line	
			350	447	449	510	line	
	Pulse width	TVp	all	2	-	34	line	
Horizontal display period		THd	"	640	640	640	clock	
Hsync-Clock phase difference		THc	"	10	-	Tc-10	ns	
Hsync-Vsync phase difference		TVh	"	0	-	TH-THP	clock	

Note) In case of lower frequency, the deterioration of the display quality, flicker etc. , may be occurred.

### 7-2. Horizontal display position

The horizontal display position is determined by ENAB signal and the input data corresponding to the rising edge of ENAB signal is displayed at the left end of the active area.

Parameter		Symbol	Mode	Min.	Typ.	Max.	Unit	Remark
ENAB signal	Setup time	Tes	all	5	-	Tc-10	ns	
	Pulse width	Tep	"	2	640	640	clock	
Hsync-ENAB signal phase difference		The	"	44	-	164	clock	

Note) When ENAB is fixed "Low", the display starts from the data of C104(clock) as shown in Fig.2-①~③. Be careful that the module do not work when ENAB is fixed "High".

### 7-3. Vertical display position

The vertical display position is automatically centered in the active area at each mode of VGA, 480-, 400- and 350-line mode. Each mode is selected depending on the polarity of the synchronous signals described in 4-1 (Note1).

In each mode, the data of TVn is displayed at the top line of the active area. And the display position will be centered on the screen like the following figure when the period of vertical synchronous signal, TV, is typical value.

In 400-line and 350-line mode, the data in the vertical data invalid period is also displayed. So, inputting all data "O" is recommended during vertical data invalid period.

ENAB signal has no relation to the vertical display position.

mode	V-data start(TVs)	V-data period(TVd)	V-display start(TVn)	Unit	Remark
480	34	480	34	line	
400	34	400	443-TV	line	
350	61	350	445-TV	line	

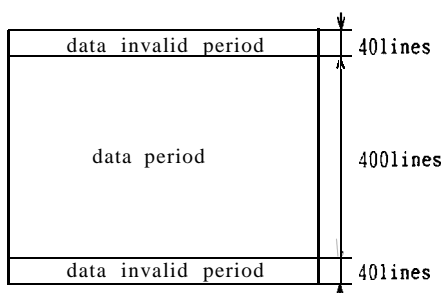

400-line mode (TV=449)

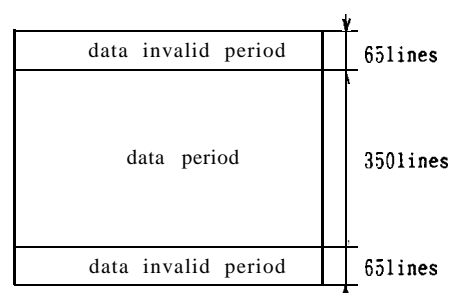

350-line mode (TV=449)

## 7-4. Input Data Signals and Display Position on the screen

Display position of input data (480-line mode)  
(H·V)

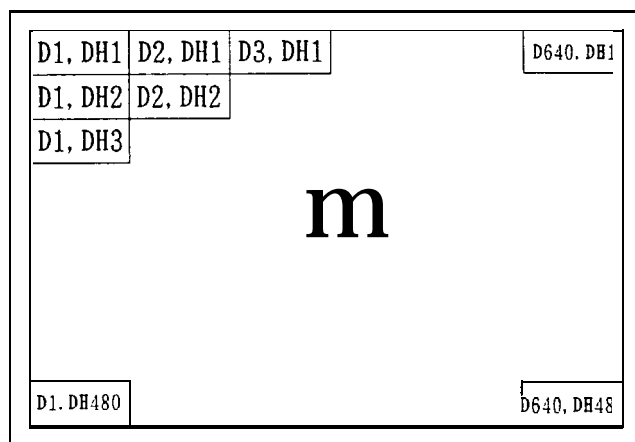

↑ UP

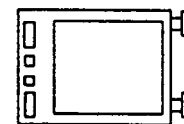

(NBH=H or open)  
(NBV=L or open)



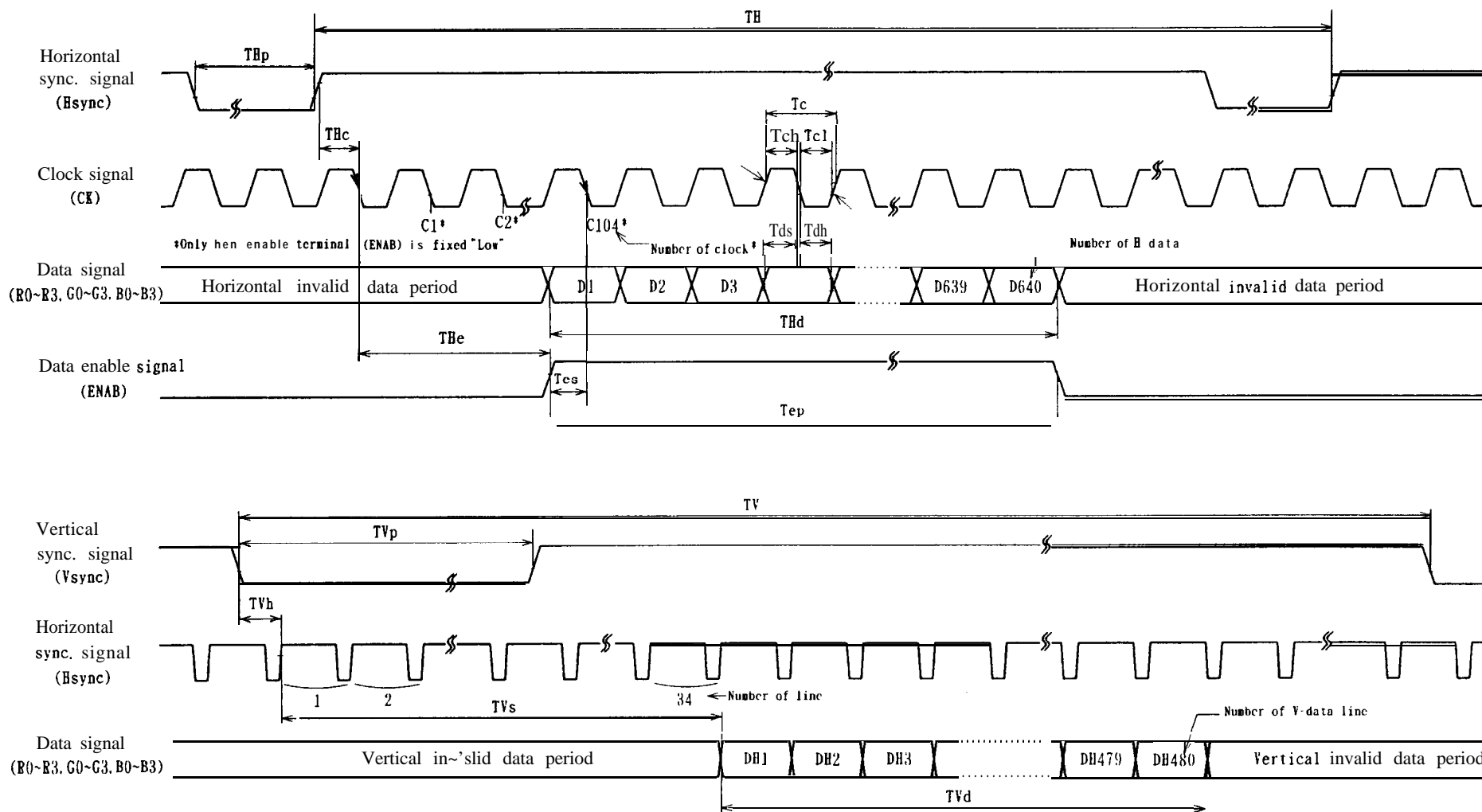

Fig. 2-① Input signal waveforms (480-line mode)

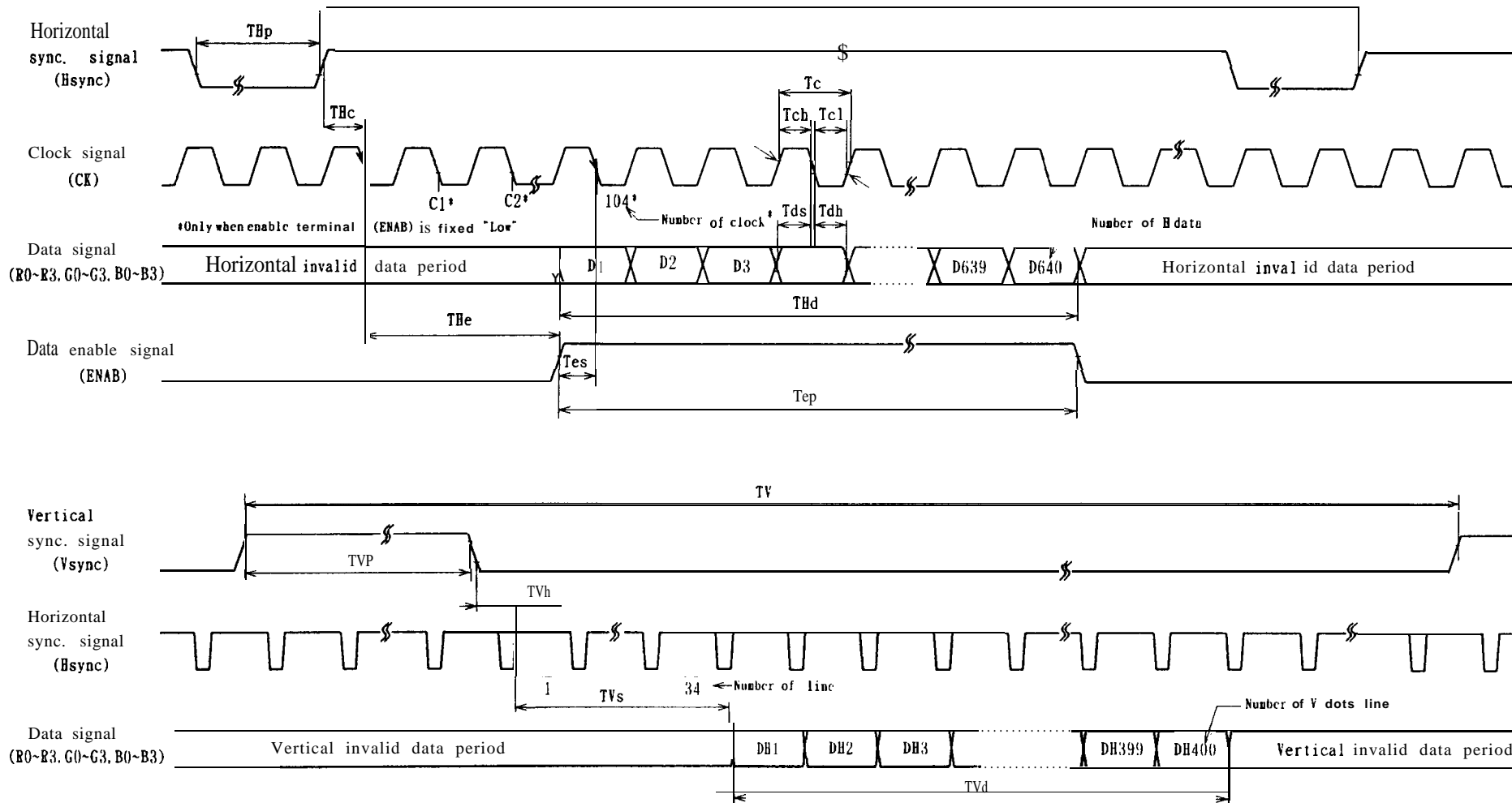

Fig. 2-② Input signal waveforms (400-line mode)

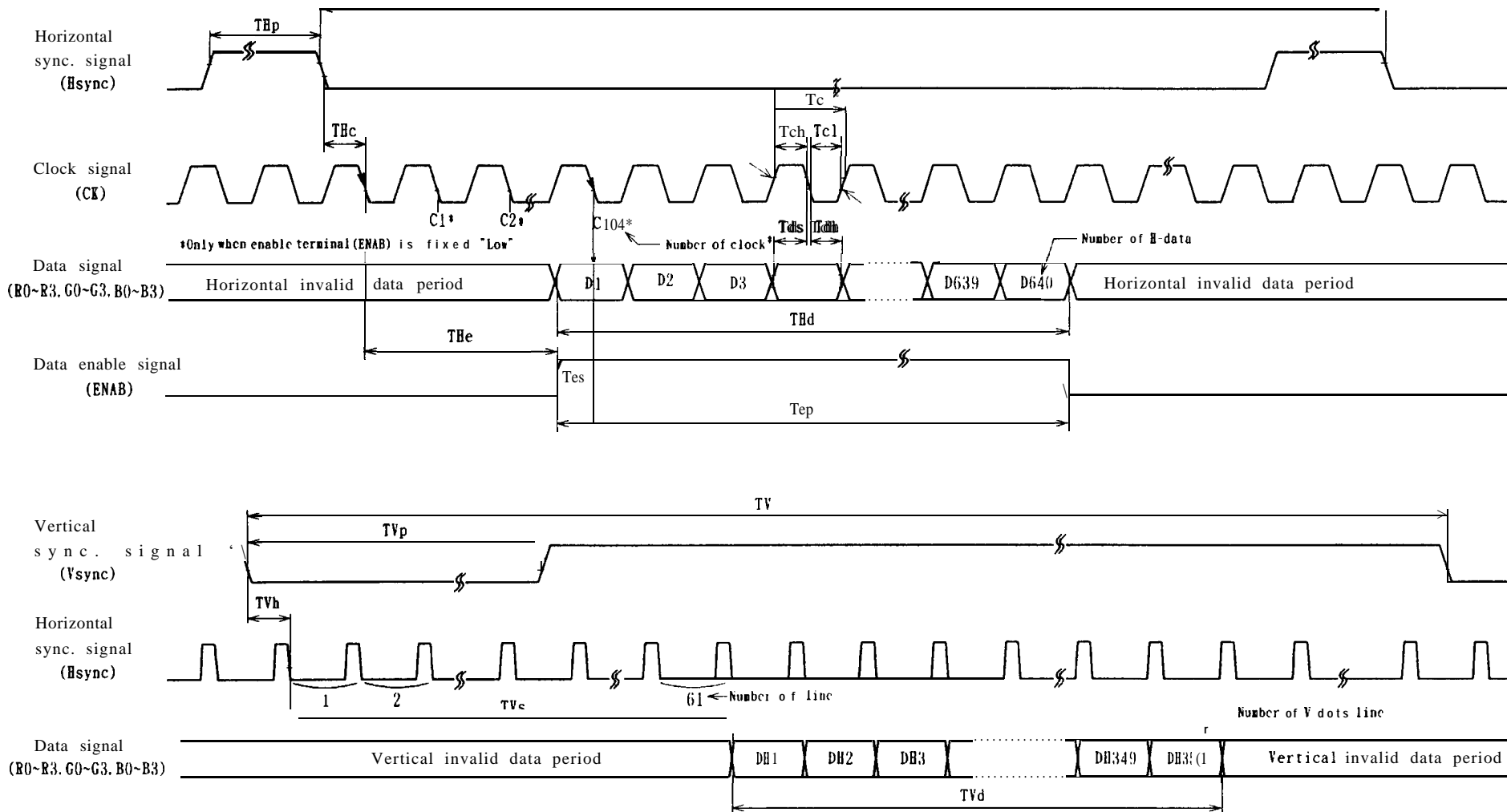

Fig. 2-③ Input signal waveforms (350-line □ ode)

## 8. Input Signals, Basic Display Colors and Gray Scale of Each Color

Color & Gray scale(GS)	GS	Data signal															
		R0	R1	R2	R3	G0	G1	G2	G3	B0	B1	B2	B3				
Black	-	1	0	0	0	0	1	0	0	0	0	1	0	0	0	0	0
Blue	-	0	0	0	0	0	0	0	0	0	0	1	1	1	1	1	1
Green	-	1	0	0	0	0	1	1	1	1	1	1	0	0	0	0	0
Light blue	-	0	0	0	0	1	1	1	1	1	1	1	1	1	1	1	1
Red		1	1	1	1	0	0	0	0	0	0	0	0	0	0	0	0
Purple		1	1	1	1	0	0	0	0	0	0	1	1	1	1	1	1
Yellow		1	1	1	1	1	1	1	1	1	1	0	0	0	0	0	0
White	-	1	1	1	1	1	1	1	1	1	1	1	1	1	1	1	1
Black	GS0	0	0	0	0	0	0	0	0	0	0	0	0	0	0	0	0
Gray Scale of Red	↑	GS1	1	0	0	0	0	0	0	0	0	0	0	0	0	0	0
	↕	GS2	0	1	0	0	0	0	0	0	0	0	0	0	0	0	0
	↕																
	↕	GS13	1	0	1	1	1	0	0	0	0	1	0	0	0	0	0
	↕	GS14	0	1	1	1	0	0	0	0	0	0	0	0	0	0	0
Red	GS15	1	1	1	1	0	0	0	0	0	0	0	0	0	0	0	0
Black	GS0	0	0	0	0	0	0	0	0	0	0	0	0	0	0	0	0
Gray Scale of Green	↑	GS1	0	0	0	0	1	0	0	0	0	0	0	0	0	0	0
	↕	GS2	0	0	0	0	0	1	0	0	0	0	0	0	0	0	0
	↕																
	↕	GS13	0	0	0	0	1	0	1	1	0	0	0	0	0	0	0
	↕	GS14	0	0	0	0	0	1	1	1	0	0	0	0	0	0	0
Green	GS15	0	0	0	0	1	1	1	1	0	0	0	0	0	0	0	0
Black	GS0	0	0	0	0	0	0	0	0	0	0	0	0	0	0	0	0
Gray Scale of Blue	↑	GS1	0	0	0	0	0	0	0	0	1	0	0	0	0	0	0
	↕	GS2	0	0	0	0	0	0	0	0	0	1	0	0	0	0	0
	↕																
	↕	GS13	0	0	0	0	0	0	0	0	1	0	1	1	1	1	1
	↕	GS14	0	0	0	0	0	0	0	0	0	1	1	1	1	1	1
Blue	GS15	0	0	0	0	0	0	0	0	1	1	1	1	1	1	1	1

0: Low level  
voltage  
1: High level  
voltage

Each basic color can be displayed in 16 gray scales from 4 bit data signals.

According to the combination of total 12 bit data signals, the 4,096-colors display can be achieved on the screen.

## 9. Optical Characteristics

Ta=25℃, Vcc=+5.0V

Parameter	Symbol	Condition	Min.	Typ.	Max.	Unit	Remark	
Viewing angle range	Horizontal	$e_{21, 22}$	$CR > 10$	35	-	-	Deg.	【Note1, 4】
	Vertical	$\theta_{11}$		10	-	-	Deg.	
		$e_{12}$		30	-	-	Deg.	
Contrast ratio	CR	$e = 0^\circ$	60	-	-		【Note2, 4】	
Response time	Rise		$\tau_r$	-	30	-	ms	【Note3, 4】
	Decay		$\tau_d$	-	50	-	ms	
Chromaticity of white	x			-	0.313	-		[Note4]
	y		-	0.329	-			
Luminance of white	$Y_L$	$I_L = 3.2\text{mA}$	[100]	120	-	$\text{cd}/\text{m}^2$	【Note4】	
White Uniformity	$\delta_w$		-	-	1.45		【Note5】	

Note) The measurement shall be executed 30 minutes after lighting at rating. ( $I_L = 3.2\text{mA}$ )

The optical characteristics shall be measured in a dark room or equivalent state with the method shown in Fig.3.

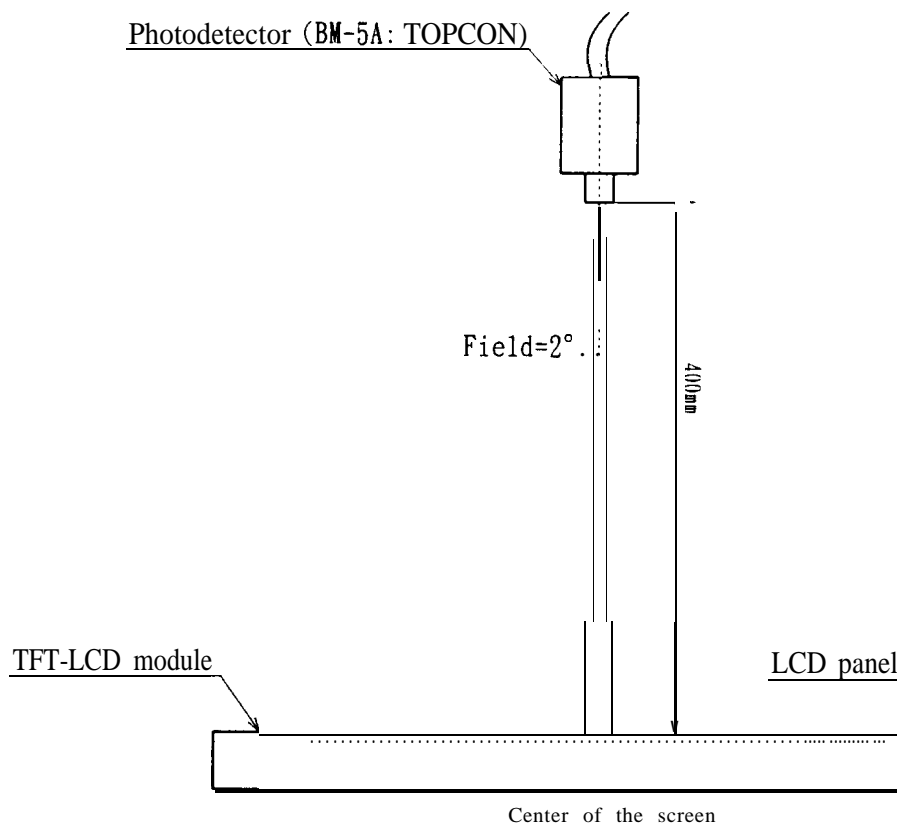
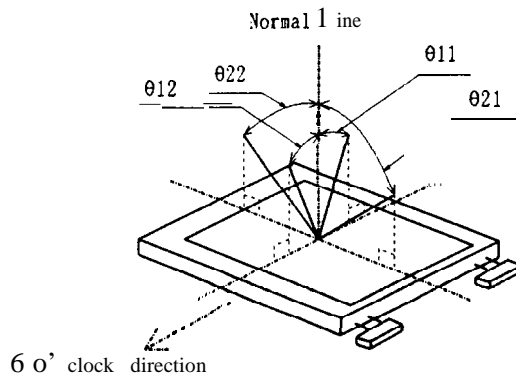

Fig.3 Optical characteristics measurement method

【Note1】 Definitions of viewing angle range:



【Note2】 Definition of contrast ratio:

The contrast ratio is defined as the following.

$$\text{Contrast Ratio (CR)} = \frac{\text{Luminance (brightness) of "white"}}{\text{Luminance (brightness) of "black"}}$$

【Note3】 Definitions of response time:

The response time is defined as the following figure and shall be measured by switching the input signal for "black" and "white".

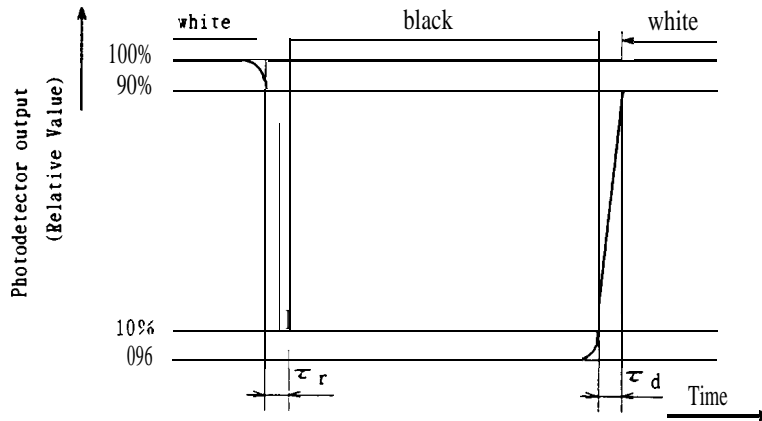

【Note4】 This shall be measured at center of the screen.

【Note5】 Definition of white uniformity:

White uniformity is defined as the following by five-point(A~E) measurements.

$$\delta_w = \frac{\text{Maximum Luminance of five-point data}}{\text{Minimum Luminance of five-point data}}$$

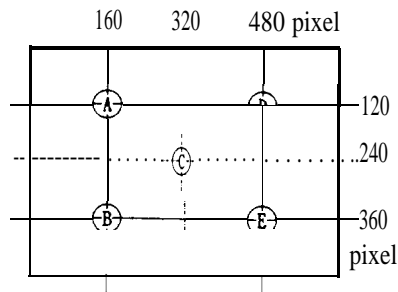

10. Display Quality

The display quality of the color TFT-LCD module shall be in compliance with the Incoming Inspection Standard.

## 11. Handling Precautions

11-1. Be sure to turn off the power supply when inserting or disconnecting the cable.

11-2. Since LCD panel is made of glass, it may break or crack if it's dropped or bumped.

Handle with care.

11-3. The thin liquid crystal layer is packed in the LCD panel. This layer may be disturbed by the external force when the panel surface is pushed strongly and this disturbance may cause the transient display non-uniformity. So do not push the panel surface so strongly. If the disturbance occurs, keep the power off for a while.

11-4. Others

- a) Be sure to design the cabinet so that the module can be installed without any extra stress such as warp or twist.
- b) Since the front polarizer is easily damaged, pay attention not to scratch it.
- c) Wipe off water drop immediately. Long contact with water may cause discoloration or spots.
- d) When the panel surface is soiled, wipe it with absorbent cotton or other soft cloth.
- e) Since CMOS LSIS are used in this module, take care of static electricity and ensure the human earth when handling.
- g) Observe all other precautionary requirements in handling components.

## 12. Reliability test items

No.	Test item	Conditions
1	High temperature storage test	Ta=60℃ 240h
2	Low temperature storage test	Ta=-25℃ 240h
3	High temperature & high humidity operation test	Ta=40℃; 95%RH 240h (No condensation)
4	High temperature operation test	Ta=50℃ 240h (The panel temp. must be less than 60℃)
5	Low temperature operation test	Ta=0℃ 240H
6	Vibration test (non-operating)	Frequency: 10~57Hz/Vibration width (one side) : 0.075mm : 58~500Hz/Gravity: 9.8m/s <sup>2</sup> Sweep time: 11 minutes Test period: 3 hours (1 hour for each direction of X, Y, Z)
7	Shock test (non-operating)	Max. gravity: 490m/s <sup>2</sup> Pulse width: 11ms, sine wave Direction: ±X, ±Y, ±Z once for each direction.

### [Evaluation Criteria]

There shall be no change which may affect the practical use of this display under the Display Quality Test conditions.

### 13. Others

- 1) Lot No. Label:
- 2) Adjusting volume have been set optimally before shipment, so do not change any adjusted value. If adjusted value is changed, the data mentioned in this technical literature may not be satisfied.
- 3) Disassembling the module can cause permanent damage and should be strictly avoided.
- 4) If any problem occurs in relation to the description of this technical literature, it shall be resolved through discussion with spirit of cooperation.



